

24.95m Kantoorschip

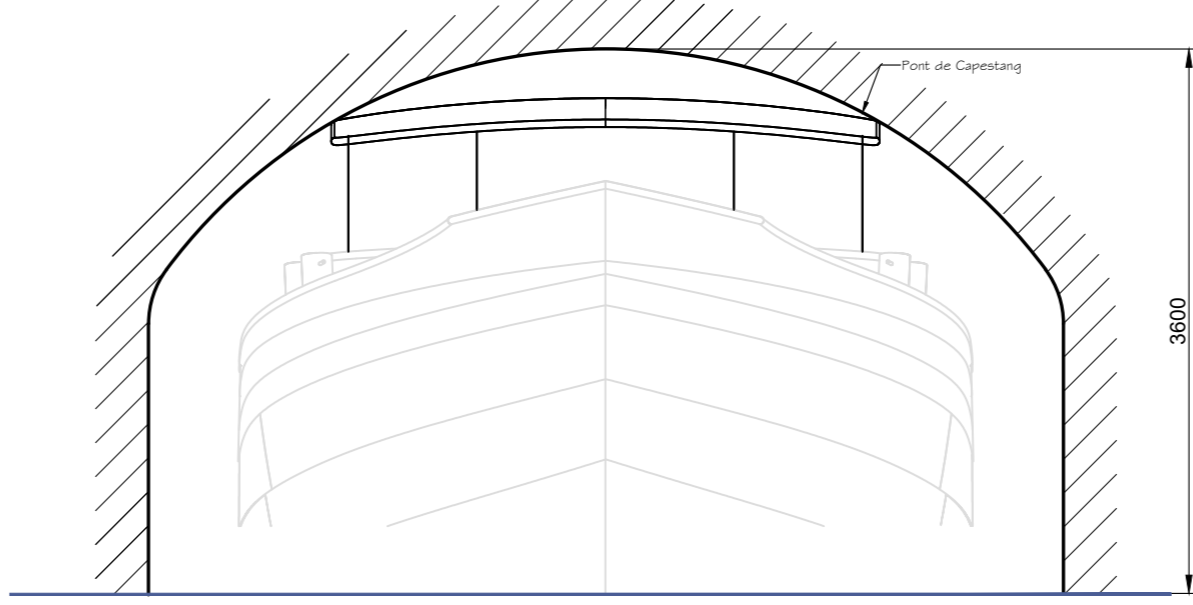

| Main dimensions | |
|-----------------|------------|
| Lenght | 24.95 m |
| Width | 4.95 m |
| Draft | plm. 1.15m |
| Moulded Depth | 2.05m |
| Displacement | |
| Air draft | 3.40m |

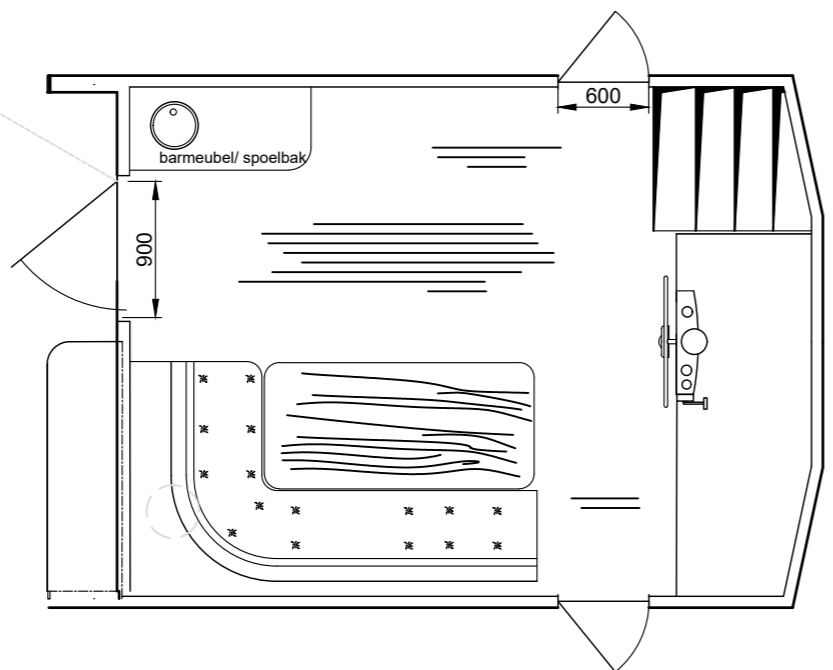
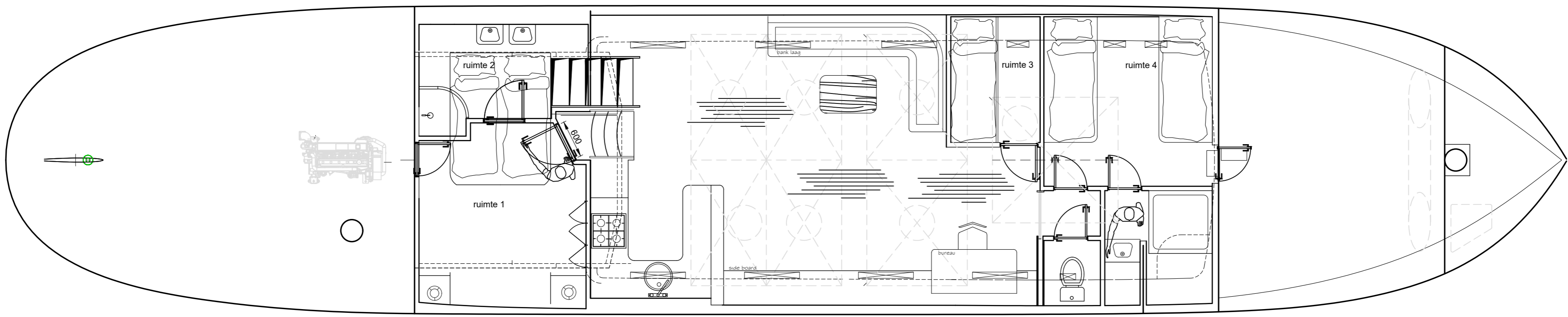
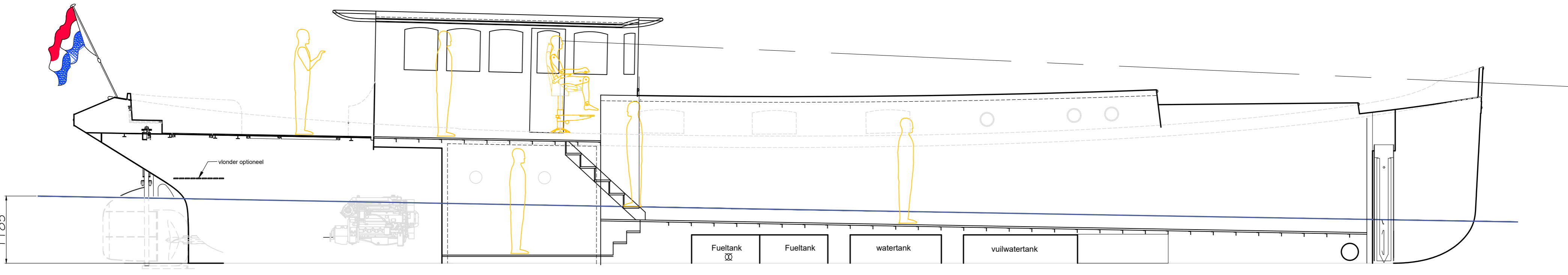
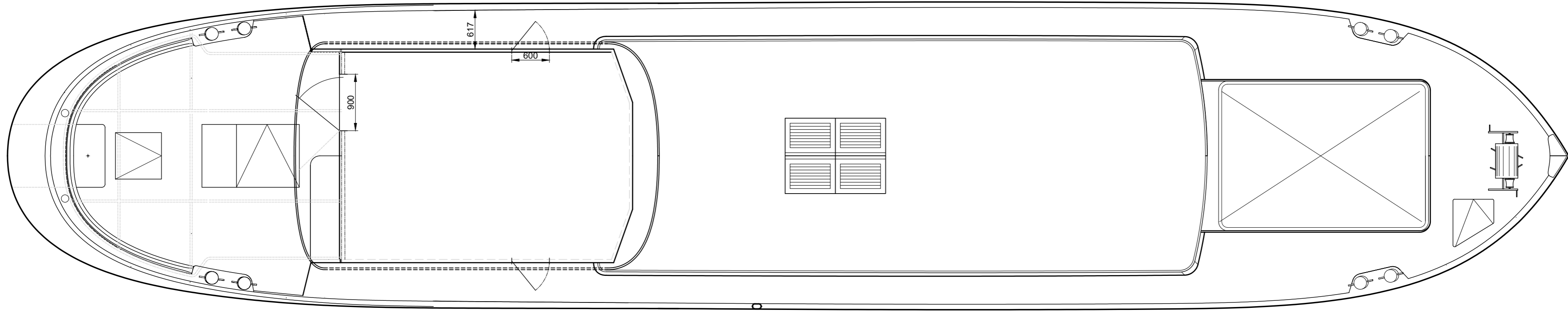
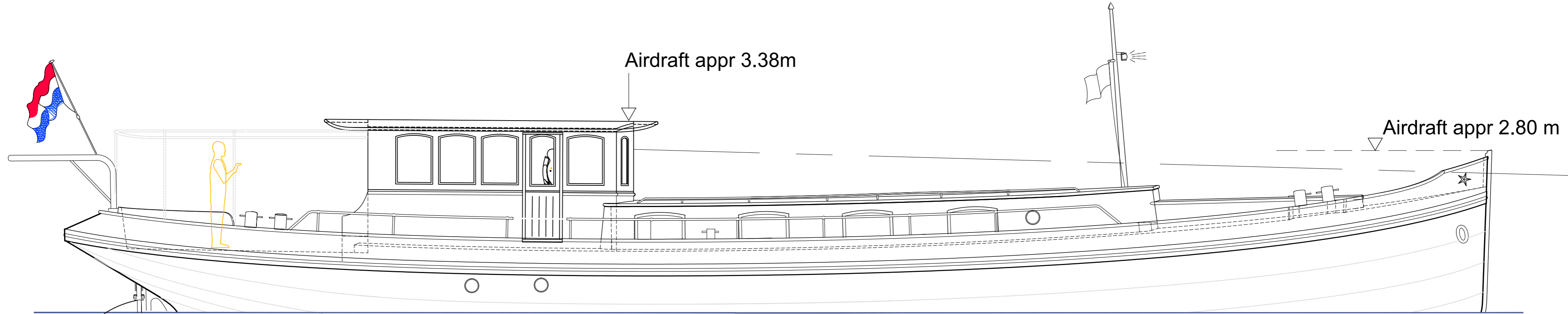
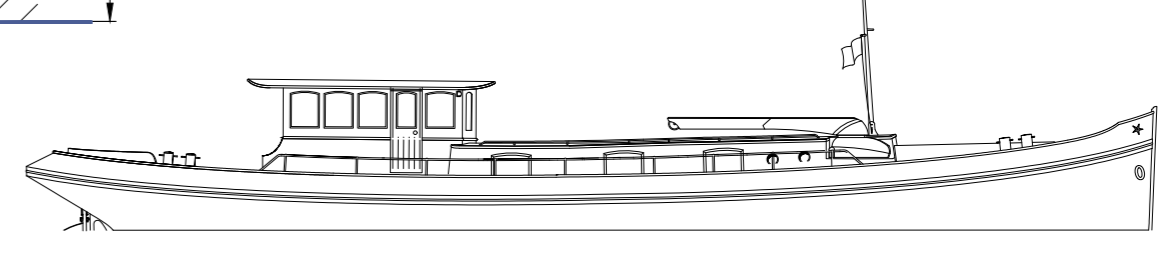

opmerking:
 • autokraan aangegeven ter indicatie:
 type, positie en constructie nog te bepalen

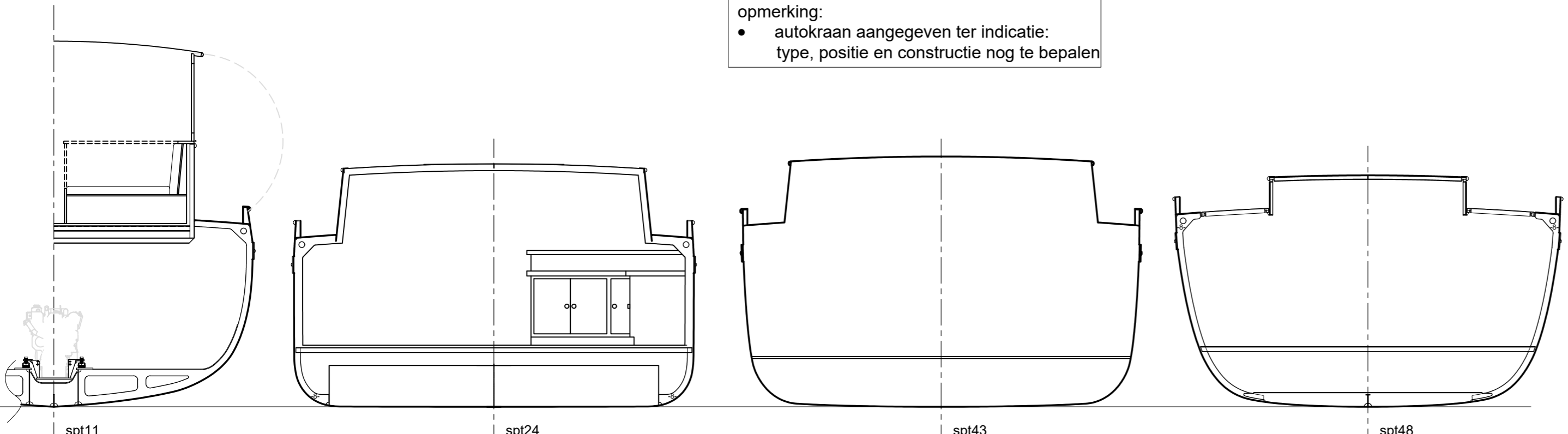

| | | | | | |
|--|------------------------|--|--------|---|----------|
| Yacht Design, Naval Architecture & Engineering Gaastmeer | | Langstraat 3 8611 JN Gaastmeer The Netherlands www.gaastmeerdesign.nl | | T +31 (0) 515 469999 F +31 (0) 515 469800 e-mail: info@gaastmeerdesign.nl | |
| Project: | Kantoorschip 24.95 | | | Projectnr.: | 1123 |
| Title: | Algemeen plan indeling | | | Drawingnr.: | A01 |
| Order: | SRF | Drawn by: | HD | Date: | nov 2012 |
| | | Scale: | 1 : 50 | Class: | |
| All rights of this design and details are reserved. | | | | | |
| | | | | | A1 |